

KNAUF

***PERMAROCK®
RESIDENTIAL EXTERNAL
CLADDING SYSTEM***

PERMAROCK® Cement Board Outdoor

PERMAROCK®

Build on us.



System introduction

PERMAROCK® Residential External Cladding System is a high-performance, economical and lightweight solution for external walls.

Outstanding protection against high humidity and moisture

This high-performance residential system is an ideal solution for exterior cladding, especially those exposed to moisture, heavy wind loads, and harsh coastal environments. Engineered and rigorously tested, its components deliver the highest standards of performance and durability in construction.

Our PERMAROCK® Cement Board Outdoor is naturally water-resistant and made from inorganic materials, that prevents the formation and spread of mould and mildew.

Complete Knauf system

With PERMAROCK® Residential External Cladding System you get a complete Knauf solution from the internal environment, incorporating Knauf plasterboard and insulation, to the external with the wall membrane from Proclima. PERMAROCK® products and systems have been extensively tested to meet the requirements of the National Construction Code and relevant Australian Building Standards.

Plasterboard: Knauf plasterboard to suit a variety of internal applications

Framing: Timber framing system designed to support PERMAROCK® Cement Board Outdoor

Insulation: Knauf glasswool insulation with a variety of thermal values to suit numerous applications

Weather barrier: Proclima Solitex Extasana

External Cladding: PERMAROCK® Cement Board Outdoor

Options for external finishes

Knauf recommends a proprietary render system from specialist companies such as Sto, Dulux, Euromix and Astec or equivalent, as well as tiles.



Render Finish



Tile Finish

Engineering and project support

Our team of engineers and specification managers will provide you with support throughout the project; from conceptual design, to reviewing architectural drawings and site support to help you ensure optimum performance in design and construction.

PERMAROCK®

CEMENT BOARD OUTDOOR

Benefits

- › Simple installation
 - › Easy to cut, score and snap
 - › No pre-drilling for fasteners
 - › Resistant to moisture and driving rain
 - › Mould and mildew-resistant
 - › Dimensionally stable, robust and durable
 - › Not deemed combustible (AS 1530.1-1994)
 - › Fire resistant - adhere to Bushfire Attack Level (BAL) requirements, up to BAL40 in accordance with AS 3959-2018
 - › Creative design opportunities
 - › Options for the creation of curved exterior claddings
 - › Spectacular seamless surfaces, thanks to expansion joints that are only needed every 15 m to enable a 225 m² closed area without a visible joint*
- › Timber frame external cladding with PERMAROCK® Cement Board Outdoor. Proclima Solitex Extasana weather barrier system and proprietary render system fulfills the AS/NZS 4284 requirements and complies to the NCC F3V1 and H2V1.
 - › System tested in Australia and/or independently certified by Venn Engineering to satisfy requirements for weatherproofing F3V1 & H2V1.
 - › Suitable for external wind pressure of +1.19 kPa & -1.79 kPa when determined in accordance with AS/NZS 1170.2:2021 or N⁵ wind classification when determined in accordance with AS 4055:2021.

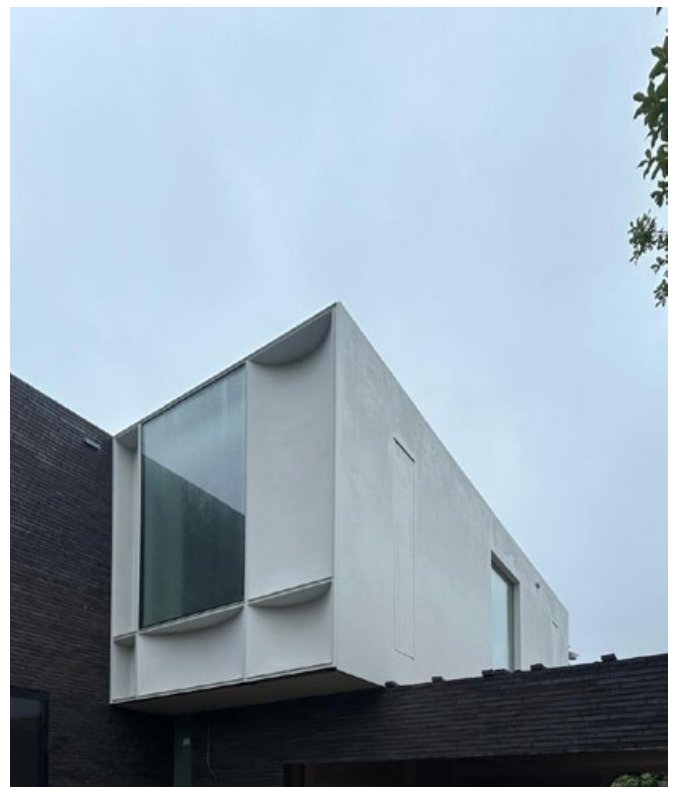

*A control/movement joint must be installed if there is a control/movement joint in the structure underneath.

Physical properties - PERMAROCK® Cement Board Outdoor

Length (mm)	3,000
Width (mm)	1,200
Thickness (mm)	12.5
Min. bending radius for 1,200 mm wide board (m)	3
Min. bending radius for 300 mm wide strip (m)	1
Weight (kg/m ²)	approx. 16
Dry bulk density (kg/m ³) according to EN 12467	approx. 1,150
Bending strength (MPa) according to EN 12467	≥ 7
Tensile strength perpendicular to the plane of the board (N/mm ²) according to EN 319	0.65
Shearing strength (N) according to EN 520	607
pH-value	12
Thermal conductivity (W/mK) according to EN ISO 10456	0.35
Thermal expansion (10 ⁻⁶ K ⁻¹)	7
Water vapour diffusion coefficient μ (-) according to EN ISO 12572	66
Length variation 65% - 85% humidity (mm/m) according to EN 318	0.23
Thickness variation 65% - 85% humidity (%) according to EN 318	0.2
Building material class according to AS 1530.1-1994	NOT deemed COMBUSTIBLE





Bend the rules of design

PERMAROCK® Cement Board Outdoor can be bent with a radius of 3 m (full board) and 1 m (300 mm strips).

For truly unique designs, use double studs.

This technique enables you to create walls with distinct interior and exterior profiles, such as a surface that curves inward on the outside and outward on the inside.

Arrangement of PERMAROCK® Cement Board Outdoor with different radii

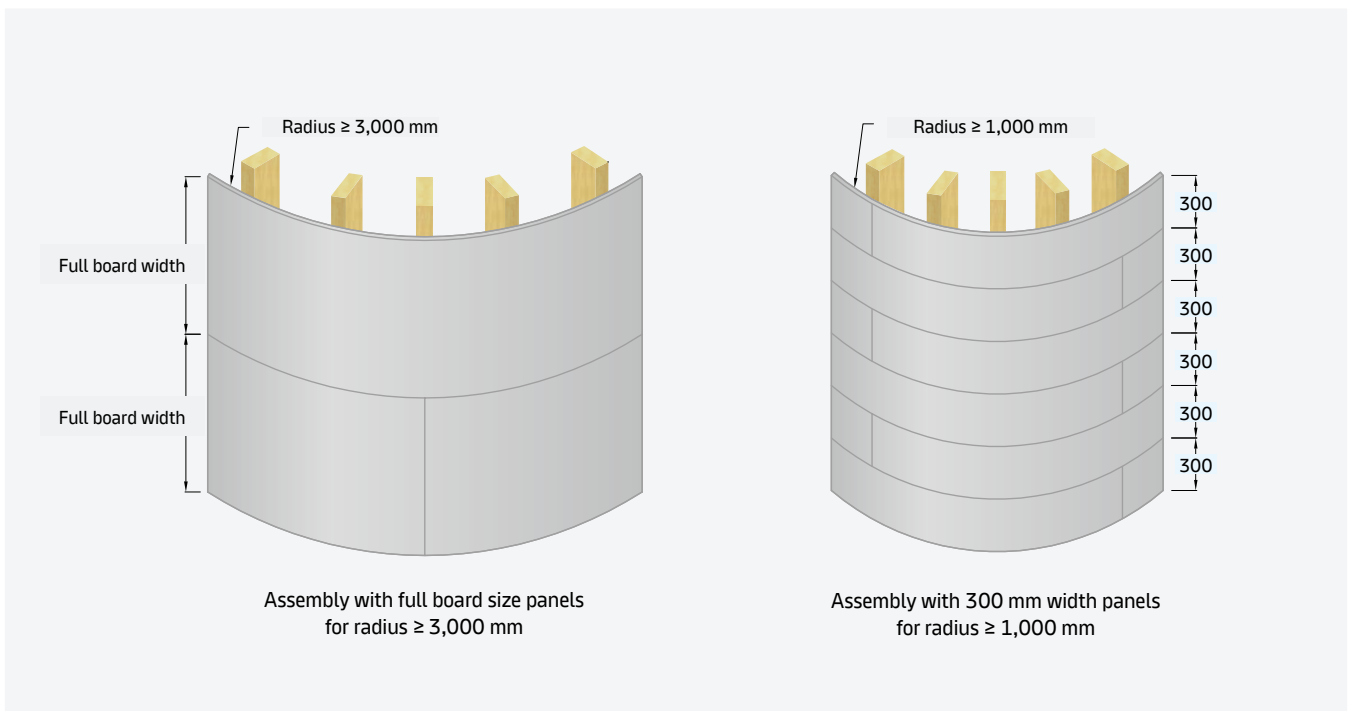

PERMAROCK® Residential External Cladding System

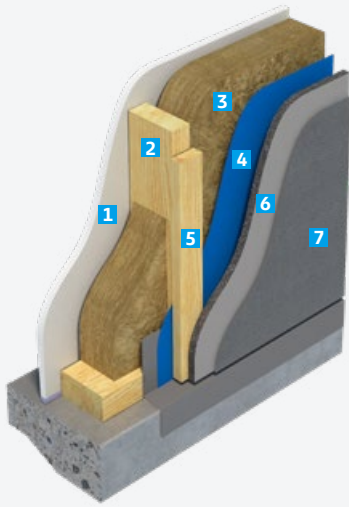

1. Knauf plasterboard as per requirements
2. Timber frame as per structural requirements
3. Knauf Insulation to achieve thermal performance
4. Proclima Solitex Extasana weather barrier
5. Timber batten minimum 70 mm wide
6. PERMAROCK® Cement Board Outdoor
7. Proprietary render system or tiled finish



Scan for [CAD Library](#)

System tested in Australia and/or independently certified by Venn Engineering to satisfy requirements for weatherproofing F3V1 & H2V1.

Overall Total Thermal Resistance, R_t

	winter	summer
50G14 glasswool R1.26, 50 mm	1.82	1.71
90G24 glasswool R2.61, 90 mm	2.54	2.42
90G32 glasswool R2.73, 90 mm	2.60	2.48

Note: Calculated by James M Fricker Pty Ltd in accordance with AS/NZS 4859.1:2018 and AS/NZS 4859.2:2018 standards.

The calculations follow the isothermal planes method and area-weighted averaging as per AS/NZS 4859.2:2018 Clause 4.3, considering in-service conditions, including adjustments for temperature and infrared emittance. Results are specific to the described systems and may vary if construction details differ.



Installation

Step 1: Timber Framing Inspection Prior To Lining Installation

Contractor to inspect installed timber stud framing and ensure it meets local regulatory standards and tolerances guidelines prior to installing PERMAROCK® Cement Board Outdoor. Seek builders' guidance as required.

Step 2: Weather Barrier Installation

Install Proclima SOLITEX EXTASANA® weather barrier onto the vertical timber studs following Proclima assembly guidelines and local regulations. Ensure any penetrations/openings (windows, pipes, cables etc.) in the weather barrier is treated adequately to maintain performance, refer Proclima for details.

Note: The minimum width of the timber batten is 70 mm.



[Proclima Guide](#)

Step 3: Thermal Break and Top Hats Installation

Install the timber vertical battens on top of the Proclima SOLITEX EXTASANA® membrane as per Proclima assembly guidelines.

Note: The minimum width of the timber batten is 70 mm.

Step 4: PERMAROCK® Cement Board Outdoor Installation

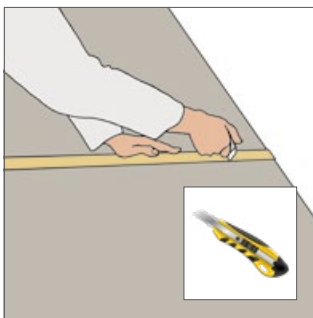

4.1 Mark the desired shape or opening on the board with pencil and ruler. Use a knife to score the cement on one side along the line so that the mesh is cut. Snap the scored edge and cut the mesh/paper on the rear side.

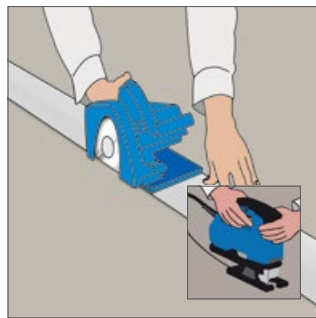

4.2 For sharp-edged cuts, for example, exterior edges, use a hand-held circular saw with a dust extractor or a pendulum jigsaw. It is recommended to use a carbide or diamond-tipped saw blade that is fully circular with no teeth.

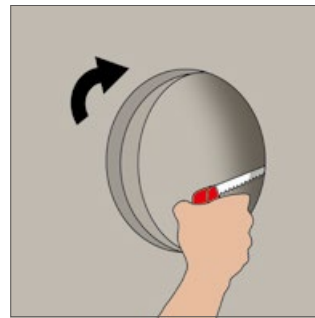

4.3 To make cut-outs for wiring and pipes, use a jigsaw or hole saw. The diameter of the opening should be approximately 10 mm greater than the diameter of the pipe. The remaining gap can be closed with a cuff, suitable sealant or sealing strip.

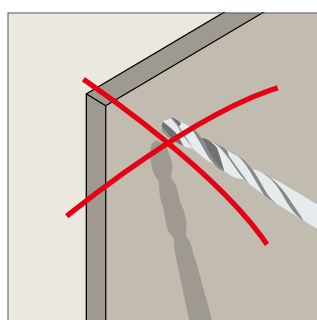
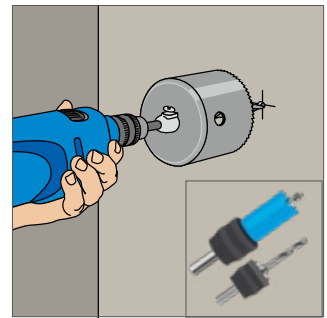

4.4 Generally, no pre-drilling of boards is required. However, pre-drilling of boards and profiles is needed if the material thickness of the profiles exceeds 2 mm (according to static requirements) or when blind rivets are used instead of screws.

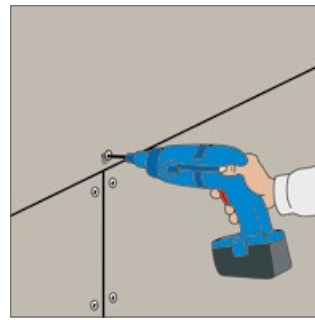

4.5 To fasten the boards with screws, use a screw gun with depth stop (comprising overturned sleeve and a stop sleeve). This ensures that all screws are countersunk in the same correct way. Fasten PERMAROCK® Cement Board Outdoor to the top hat frame with Knauf Maxi Screws. First, fasten the screws in the center of the cement boards, then work towards the edges. During installation, make sure the cement boards fit closely to the substructure. Screws should not be overtightened

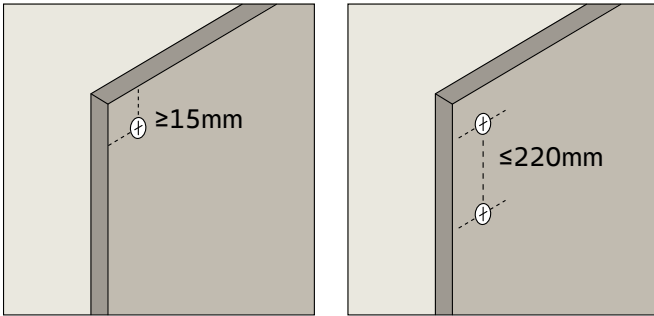

4.6 Follow rules of distances: the screw spacing must not exceed 220 mm and the spacing from the edge must be at least 15 mm.

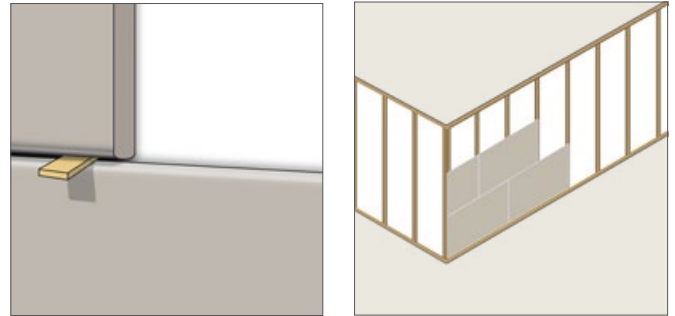

4.7 Apply PERMAROCK® Cement Board Outdoor panels horizontally. Arrange front edge joints (vertical) on centre of the timber batten. Leave a gap of 3-5 mm between boards alongside the long and front edges (horizontal and vertical) using a suitable spacer. Front edge joints (vertical) must be staggered by at least one timber batten spacing.

Note: The membrane and vertical timber batten are not shown for clarity. Hairline cracks on the surface of PERMAROCK® Cement Board Outdoor are no indications of loss of strength or function, as long as embedded glass fibre mesh is intact.

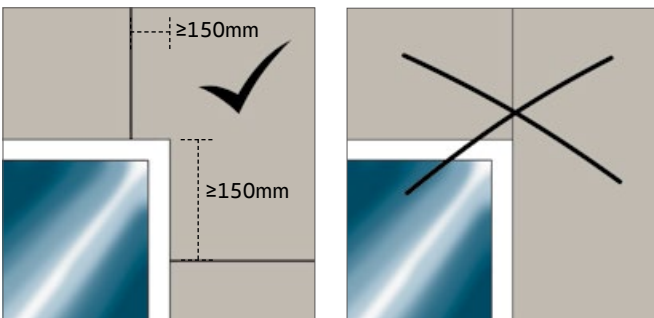

4.8 Take the boards up to the parapet, reveals and parapet of the window or the door. There must be no continuous joints as these could lead to cracks and leaks. The spacing between the board joints and the imaginary extensions (horizontal and vertical) of the window frames has to be at least 150 mm.

Board vertical edges alignment with openings is not recommended.

Step 5: Joint Treatment Installation

Apply the proprietary joint treatment in accordance with the manufacturer’s assembly guidelines and recommendations.

Finish Options

OPTION 1 – Render Finish

Step 6: Install the proprietary exterior render and texture system as per the manufacturer’s assembly guidelines and recommendations. Refer to companies, such as Sto, Dulux, Astec, Masterwall, Rockcote and Euromix.

OPTION 2 – Tiled Finish

Step 6: Prime the surface as per Ardex specifications and assembly guidelines.

Step 7: Apply waterproofing (if required) using Ardex specifications and assembly guidelines.

Step 8: Install the tiles using Ardex tile adhesive as per the manufacturer’s assembly guidelines.

Step 9: Grout tiles to Ardex specification at least 24 hours after applying the tile adhesive following Ardex assembly guidelines.

Residential External Cladding Projects



Private House



Natural 1



Z Line House



Palmas Osorno

Knauf Gypsum Pty Ltd.

3 Thackeray Street,
Camellia NSW 2142
Australia

TecASSIST™ +1800 811 222

Sales Enquiries +1800 003 377

www.knauf.com

Technical Resources



CAD Library



eSelector