

BUILD A BILLYCART FOR THE KIDS



DIY WITH THE KIDS

PROJECT NO.27

Follow our step-by-step instructions and get the kids to help out with making their own set of wheels. Time to allow for this project, including paint drying is 3-4 days.

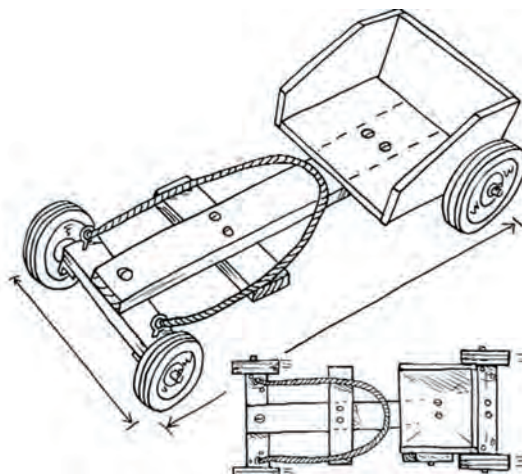

HINTS & TIPS



Use pre-dressed timber so that you don't have to sand back any raw edges. After you've cut all the measurements, paint the pieces in the colour/colours required. An undercoat and two to three coats of high-gloss exterior enamel will protect the cart from outdoor weather conditions. Where possible all metal parts should be galvanised.



TOOLS CHECKLIST

- Saw
- Drill and bits
- Straight edge
- Hammer
- Marking pencil/scraper
- Spanners
- Measuring tape



TIMBER CHECKLIST

- 75 x 50mm DAR
- Two pieces 600mm for axles
- One piece 600mm for foot rest
- 150 x 50 DAR
- One piece 1200mm
- 200 x 25mm DAR
- Two pieces 550mm for seat
- Two pieces 250mm
- 50 x 25mm DAR
- One piece 600mm for handbrake



MATERIALS CHECKLIST

- 2 x 600mm x 13mm axles and brackets
- 2 x 125mm wheels to fit front axles
- 2 x 200mm wheels to fit back axles
- 4 x split pins to fit axles
- 4 x washers to fit axles
- 4 x 100mm x 10mm cup head bolts
- 4 x 10mm nuts to fit bolts
- 4 x 10mm washers
- 12 x 50mm x 1.8mm bullet head nails
- 11 x 50mm x 8mm cup head bolts
- 11 x 8mm nuts to fit bolts
- 12 x 8mm washers
- 2 x 50 x 6mm eye bolts
- Approx 2m of rope
- 1 x 130mm x 12mm cup head bolts
- 2 x 12mm nuts to fit bolt
- 3 x 12mm washers

homehardware.com.au
for more tips, advice & for your nearest store

HOME
TIMBER & HARDWARE

GO WHERE THE TRADIES GO



STEP 1 FRONT AXLE

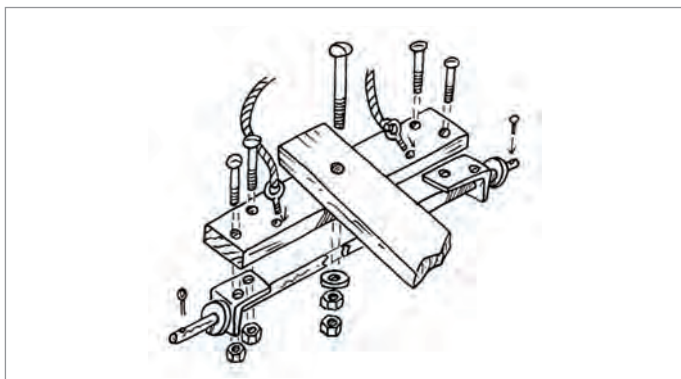

Diagram 01

Make sure that the front and rear timber axles match the length of the steel axles. You may need to saw off a small piece of a timber axle to adjust its length.

Drill a 13mm hole in the centre of the timber axle.

Position the corners of the steel axle brackets so that they are located in the lower left and lower right corners of the timber axle.

Use the pre-drilled holes in the steel axle brackets as guides for drilling holes for the 50mm x 8mm bolts that will secure the brackets to the timber axle.

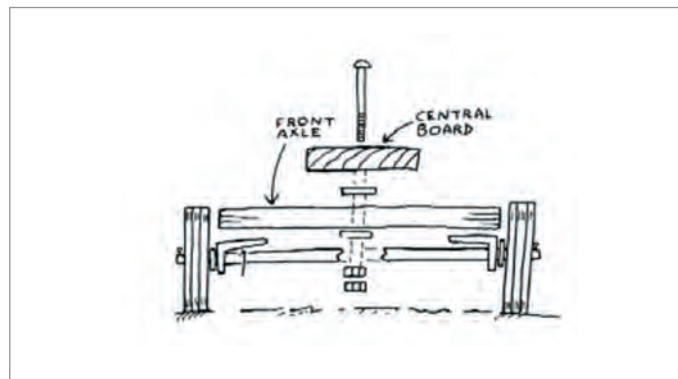

Diagram 02

Drill 8mm holes and bolt the brackets to the timber. Ensure the flat head of the bolt is on the top outside of the axle.

Drill 6mm holes for the eye bolts. Make sure the holes are clear of the steel axle brackets. Push them through and bolt them. Thread the rope through the eye bolts and secure it by tying knots either side.

Insert the steel axle through the bracket and place one axle washer against the face of either bracket. You may find that a second washer will be required to help separate the wheels from the timber axle.

STEP 2 REAR AXLE

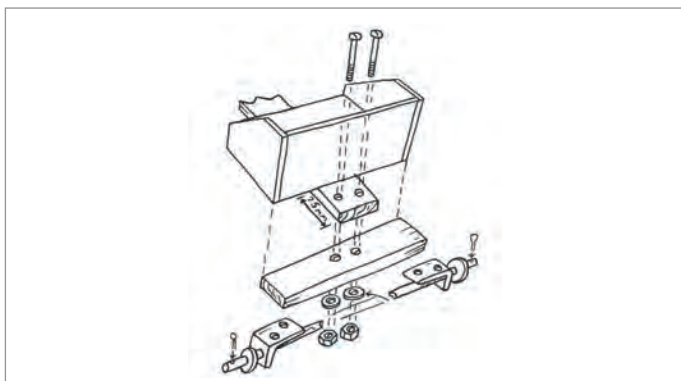

Diagram 03

Position the corners of the steel axle brackets so that they are located in the lower left and lower right corners of the timber axle.

Use the pre-drilled holes in the steel axle brackets as guides for drilling holes for the 50mm x 8mm bolts that will secure the brackets to the timber axle.

Drill 8mm holes and bolt the brackets to the timber. Ensure the flat head of the bolt is on the top outside of the axle.

Insert the steel axle through the bracket and place one axle washer against the face of either bracket. You may find that a second washer will be required to help separate the wheels from the timber axle.

STEP 3 CENTRE BOARD

Position the rear axle so that its face is flush with the edge of the centre board and drill two 10mm holes through the board and axle. Push two 100mm x 10mm bolts through and bolt the axle to the centre board.

The front axle should be set approximately 50mm beyond the face of the centre board. Use the previously drilled 10mm hole in the axle to mark a 10mm hole in the centre board. Insert the 100mm x 10mm cup head bolt, place a 10mm washer either side of the axle and use two nuts to lock the bolt in position. The steering mechanism is complete.

This information is intended as a guide only. Please check with your council for any relevant laws before commencing any work. Always wear personal protection equipment and use tools safely.



STEP 4 SEAT

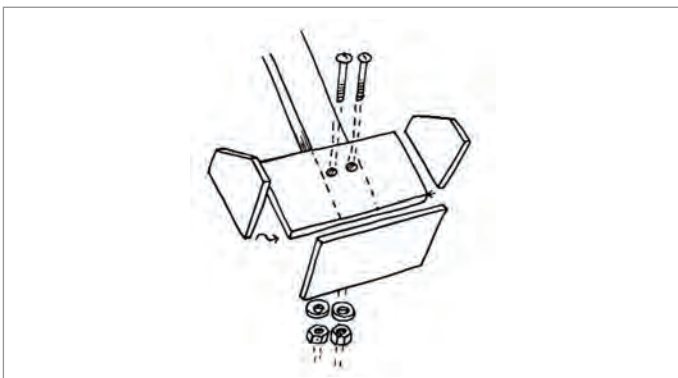

Diagram 04

Glue and nail the seat as shown in the illustration. Position the seat so that it is 75mm away from the rear of the board. Drill two holes through the base of the seat on the board so that the 8mm bolts can be bolted in position. Make the size and position of the seat suit the age and leg length of your kids.

STEP 5 BRAKE

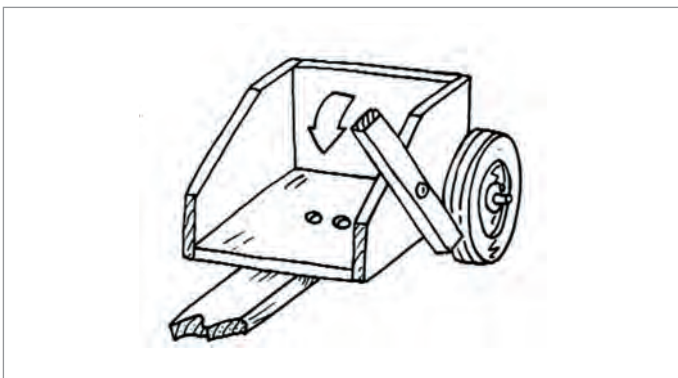

Diagram 05

Drill a hole through the centre of the brake and through the side of the seat. From the inside of the seat push the 50mm x 8mm cup head bolt through both holes. Put a washer between the brake and the seat and between the nut and the brake. Use two nuts to lock the bolt. To operate the brake push down on the lever so the other end is forced against the rear tyre tread.

STEP 6 FOOTREST

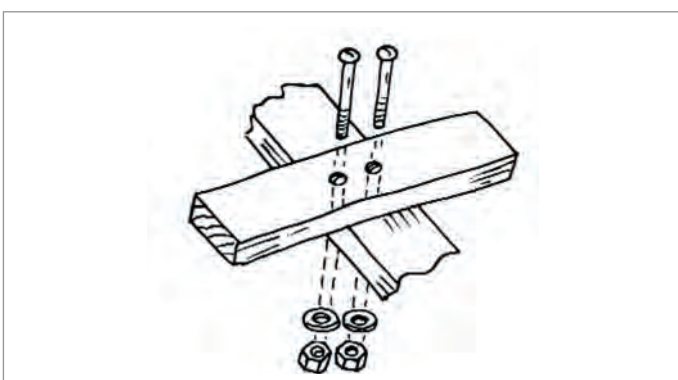

Diagram 06

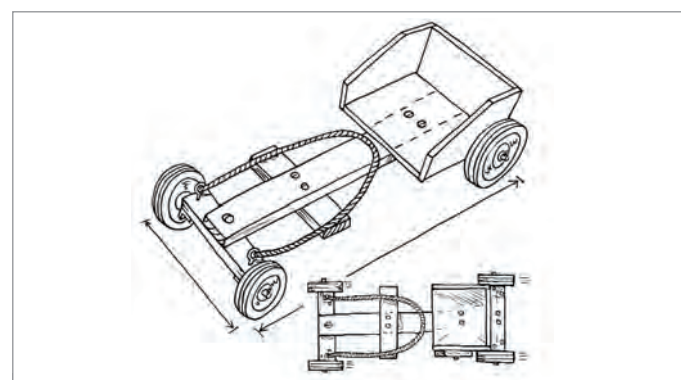

Diagram 07

Again, adjust the position of the foot rest to suit the billy cart's drivers. Drill and bolt with two 100mm x 10mm cup head bolts.

This information is intended as a guide only. Please check with your council for any relevant laws before commencing any work. Always wear personal protection equipment and use tools safely.